

[CONTRIBUTION FROM THE DEPARTMENT OF CHEMISTRY, DUKE UNIVERSITY]

The Action of Elementary Fluorine upon Organic Compounds. XIV. The Fluorination of Deactivated Aromatic Rings¹

BY ALFRED R. GILBERT² AND LUCIUS A. BIGELOW

In a preceding study³ of the fluorination of 4-chloro-1,3-bis-(trifluoromethyl)-benzene, a tetra-fluoride addition product to the ring was isolated and characterized for the first time, but no aromatic products were formed in the reaction. The present paper reports a considerable extension of this work, and deals with the fluorination of a number of progressively more and more highly deactivated aromatic compounds, namely, 1,4-difluorobenzene, benzotrifluoride, 1,4-bis- and 1,3,5-tris-(trifluoromethyl)-benzene, and has been carried out with the aim of elucidating still further the mechanism of the attack of elementary fluorine upon such structures. The compounds were fluorinated in the vapor phase over a close metal packing in the apparatus described below at a molar reaction ratio (F_2 :sample: N_2) of 3:1:12, and reaction zone temperatures from 66 to 92°, representing mild operating conditions. After the removal of hydrogen fluoride, the products were separated and carefully rectified using a Podbielniak Hyper-Cal fractionating unit. They have been characterized only with respect to quantitative composition and molecular weight, together with simple chemical and physical properties, so that the formulas presented in the charts are to be regarded as representative only, in cases where structural or stereoisomers may be present.

The over-all effect of increasing deactivation was very marked. In the case of 1,4-difluorobenzene, where the ring was least electron deficient, the reaction was accompanied by much combustion which consumed a good deal of the fluorine but essentially no polymerization occurred. Much of the sample was recovered unchanged, and no significant products other than C_6F_{12} were obtained. However, when one electron attracting trifluoromethyl group was present as in benzotrifluoride, the situation was materially altered. In this instance very little combustion occurred but instead no less than 42% of the product consisted of a viscous liquid polymer which was deposited on the surface of the reactor packing where it interacted with and consumed much of the incoming fluorine with the result that a good deal of the sample was again recovered unchanged, and only a few definite products could be isolated. Next, in the fluorination of 1,4-bis-(trifluorometh-

yl)-benzene, not only the increasing deactivation of the ring but also steric hindrance came into play, and the picture was again materially changed. In this case very little combustion took place, but the degree of polymerization was reduced to only 28% of the total product with the result that less hydrogen fluoride was formed, most of the fluorine reacted with the sample to produce relatively simple molecules and only a small amount of the original material was recovered. Finally in the last case, that of 1,3,5-tris-(trifluoromethyl)-benzene, where both the deactivation and the steric hindrance factors were at a maximum, the progressive effects just described had proceeded essentially to completion. During this fluorination relatively little heat was evolved, very little hydrogen fluoride was formed, and neither fragmentation nor polymerization took place to any appreciable extent. On the other hand, practically all the fluorine reacted with the sample to produce monomeric derivatives of cyclohexene or cyclohexane. From these considerations alone, it may safely be concluded that when an aromatic nucleus is sufficiently deactivated and hindered it may be expected to interact with elementary fluorine in an orderly and predictable manner.

The fluorination of 1,4-bis-(trifluoromethyl)-benzene which was originally selected both for inertness and symmetry, was studied most intensively. On fluorination as described above it gave rise to a liquid principal product, b. p. 64–86° at 85 mm., obtained consistently in 65% yield based on the total product. This alkali sensitive mixture, which contained between 5 and 6 fluorine atoms per mole more than the original compound, was treated as follows.

First the material was treated with ammonia in *n*-pentane solution and gave rise to a small yield of the yellow crystalline well characterized pentamine $C_6H_5(NH_2)_5(CF_3)_2$, V, m. p. 171–172.5°, while the remainder of the product was all basic and contained even less fluorine than that required by two $-CF_3$ groups. The compound V could have been formed by an exchange reaction with II, which in turn could have been produced readily during the fluorination by the addition of four atoms of fluorine and one molecule of hydrogen fluoride to the original sample. Obviously II could have contained no $-CF_2-$ group since the latter would have been inert to ammonia, and yet all of the fluorine attached to the ring had been displaced in forming V.

When the principal product was treated with as strong a base as sodium amide the exchange reac-

(1) This paper has been constructed from the Doctorate thesis presented by Alfred R. Gilbert to Duke University in March, 1949.

(2) Allied Chemical and Dye Corporation Fellow, 1947–1948. Present address: General Electric Company, Schenectady, New York. This project was also sponsored in part by the Naval Research Laboratory and aided by the Duke University Research Council. Grateful acknowledgment is hereby made for this material assistance.

(3) Paper XII, THIS JOURNAL, 68, 2187 (1946).

tion still predominated, since practically all the product was basic, but some β -elimination did occur, inasmuch as some ammonia was liberated. Also, when this material was refluxed with zinc dust, it was recovered essentially unchanged, and still yielded V when treated with ammonia. These observations indicated clearly that essentially none of the components of the mixture under study, such as II, was so constituted as to permit a return to an aromatic system on treatment with basic reagents; and no aromatic derivatives of the original compound could be isolated at any time.

Since it was shown that the original 1,4-bis-(trifluoromethyl)-benzene could be reduced catalytically at high pressures without difficulty to form the corresponding cyclohexane derivative, IX, f. p. -40° , b. p. 139.5° , the principal product already referred to was subjected to the same treatment. It yielded two products, one of which was IX, and the other was the colorless liquid compound $C_6H_8F_2(CF_3)_2$, VIII, b. p. 128° , which would not react with ammonia. Under these circumstances this compound cannot have any other structure than VIII excluding stereoisomers. Since $-CHF-$ and $-C(CF_3)F-$ groups should be sensitive to reduction, and $-CF_2-$ groups probably would not, the results of the hydrogenation indicate that the principal product contained components carrying a $-CF_2-$ group such as I and possibly the symmetrical hexafluoride itself, although neither was actually isolated.

hexane, VII, b. p. 101° .⁴ To determine the best conditions for doing this the original 1,4-bis-(trifluoromethyl)-benzene was itself fluorinated under vigorous conditions, and yielded not only VII but also two stereoisomeric dihydroperfluoro derivatives, VI, b. p. 107 and 116° , which were alkali sensitive. These compounds have been assigned a $-CH_2-$ group instead of two $-CHF-$ groups, because the latter should be more sensitive to fluorination under vigorous conditions. No corresponding monohydroperfluoro derivative could be isolated. Then the principal product itself was fluorinated under like conditions and gave a good yield of the perfluoro compound VII, thus proving that no significant cracking of any kind had occurred.

Next this same principal product was itself very carefully rectified and small amounts of two colorless, liquid, alkali sensitive products were isolated. The first of these was $C_6H_5F_5(CF_3)_2$, II, b. p. 72° at 70.5 mm., which was easily converted into the penta-amine V by ammonia in pentane solution, as expected from the previous discussion; while the second was $C_6H_2F_6(CF_3)_2$, IV, b. p. 69.3° at 70.5 mm., whose structure will be discussed below.

Finally, in addition to the principal product the original fluorination gave rise to considerable material which distilled readily at atmospheric pressure and on careful rectification yielded in addition to unchanged sample, a small quantity of a colorless, readily crystallizable liquid, $C_6H_2F_4(CF_3)_2$, III, f. p. -16 to -15° , b. p. 111.5° , which was completely inert to alkaline reagents. Since $-CHF-$ or $-C(CF_3)F-$ groups would presumably be attacked by such reagents, it would seem to be almost certain that the four additional fluorine atoms in this molecule must be contained in two $-CF_2-$ groups, which may be in the 1,4 position as in III, or in the 1,2 position. Also III could be very easily converted into IV by the simple addition of two atoms of fluorine to one of the double bonds, which was the reason for assigning the given structure to IV, although other possible arrangements would fit the analytical composition equally well. It is thus apparent that all of the fluorination products of 1,4-bis-(trifluoromethyl)-benzene may readily be accounted for on the basis of orthodox addition and substitution reactions.

The preceding results led directly to the choice of the still more deactivated sterically hindered and highly symmetrical compound 1,3,5-tris-(trifluoromethyl)-benzene for study, and the outcome has amply justified this choice. The compound was fluorinated as before and gave rise to a water-white viscous alkali sensitive liquid principal product, b. p. $66.2-82^\circ$ at 97 mm., which was obtained in a yield of 96% based on the total product. Very little heat was evolved during the reaction, and neither fragmentation nor polymerization took place appreciably, but all the fluorine ($3F_2$ per mole) was absorbed, and no un-

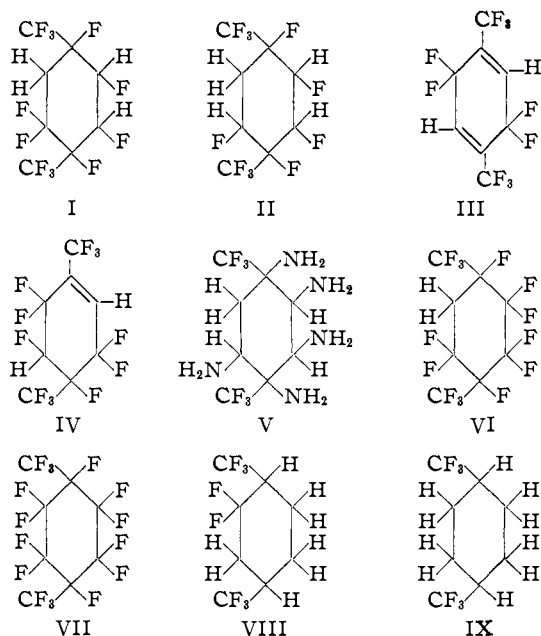

In order to prove unequivocally that no cracking had occurred during the original fluorination, it was necessary to fluorinate the principal product under vigorous conditions and to obtain a good yield of the known perfluoro-1,4-dimethylcyclo-

(4) Fowler, Hamilton, Kasper, Weber, Burford and Anderson, *Ind. Eng. Chem.*, **39**, 375 (1947).

changed sample was recovered. The principal product was carefully rectified and yielded three definite compounds, namely, $C_6H_3F_4(CF_3)_3$, X, b. p. 64.5° ; $C_6H_2F_5(CF_3)_3$, XI, b. p. 67.5° ; and $C_6H_2F_7(CF_3)_3$, XII, b. p. 74.6° , all at 106 mm., of which the last was obtained in the greatest yield, or about 13% of the total product. The first of these compounds, X, was a simple tetrafluoride of the original substance, containing two $-CHF-$ and two $-C(CF_3)F-$ groups. The second fluoride, XI, containing 5 atoms of fluorine more than the original sample, was probably formed by the fluorination of one of the $-CHF-$ groups in X and so contained one $-CF_2-$ group. The third product XII was probably formed by the addition of two fluorine atoms to the remaining double bond in XI, and it should be noted that these three compounds, X, XI and XII, were formed in progressively increasing yields and probably represented the chief path of the reaction leading ultimately to the corresponding perfluoro compound. The simple hexafluoride was not isolated at any time, although it could have been formed readily as an intermediate between X and XII. The compounds under discussion were all sensitive to alkali, yielded glasses on cooling and showed no tendency to return to aromatic systems.

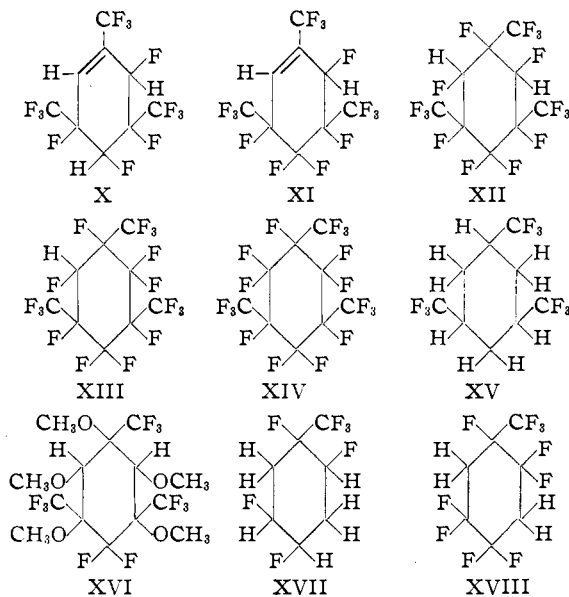

Neither X, XI nor XII could be made to yield any definite product when treated with ammonia in *n*-pentane solution, but when the heptafluoride XII containing five presumably reactive fluorine atoms was treated with sodium methoxide in methanol at -10° , there was ultimately obtained in good yield a white crystalline pentamethoxy derivative, $C_6H_2F_2(OCH_3)_5(CF_3)_3$, XVI, m. p. $69.5-70.2^\circ$, b. p. 103° at 9 mm. Here again the exchange reaction predominated completely over β -elimination, none of which was in fact observed in this case. While the original compound, 1,3,5-

tris-(trifluoromethyl)-benzene, could be catalytically reduced at high pressures to form the corresponding cyclohexane derivative, $C_6H_9(CF_3)_3$, XV, m. p. $59.2-59.8^\circ$, b. p. 157° (micro), in excellent yield, all efforts to reduce XI in a similar manner were unsuccessful.

Finally most of the principal product, excluding X, XI and XII, was recycled with an excess of fluorine under more vigorous conditions than before and the product carefully rectified. There were isolated two important compounds, namely, the known perfluoro derivative $C_6F_9(CF_3)_3$, XIV, b. p. $124-125.5^\circ$,⁴ and an alkali sensitive monohydroperfluoro derivative $C_6HF_8(CF_3)_3$, XIII, b. p. 130° . Compound XIV was formed in good yield showing that essentially no cracking had occurred during the fluorinations, while XIII, which was obtained in small quantity only, represented the last possible stage in the fluorination, intermediate between XII and XIV. No addition of hydrogen fluoride occurred during these fluorinations to form products containing a $-CH_2-$ group, since the concentration of this acid in the reaction mixtures was low, inasmuch as no polymer was present to interact with the incoming fluorine.

It was also considered desirable to fluorinate the commercially available benzotrifluoride, since it contained only one deactivating trifluoromethyl group. It was fluorinated as before, but the results were very different from those which have just been described. Although little fragmentation occurred, considerable heat was evolved during the reaction, a large amount of polymer was formed which consumed the fluorine, much unreacted sample was recovered and the concentration of hydrogen fluoride in the reaction mixture was high. One portion of the product, b. p. 54° at 149 mm. to 86° at 78 mm., amounting to 34% of the total, yielded on rectification small quantities of two significant alkali sensitive portions, namely, $C_6H_7F_4(CF_3)$, XVII, b. p. 55° , and $C_6H_4F_7(CF_3)$, XVIII, b. p. 64.5° , both at 162 mm. The first of these was believed to have been formed by the addition of two fluorine atoms to the ring, followed by the addition of two molecules of hydrogen fluoride to form a saturated fairly stable molecule. The second compound could have been produced by the further fluorination of the three $-CHF-$ groups in XVII to form XVIII, but under the circumstances the suggested structures must be regarded as representative only.

It is of interest that all of the new results which have been obtained by the fluorination of this series of more or less deactivated aromatic compounds can be explained satisfactorily on the basis of first addition, followed by various degrees of addition, substitution, polymerization and fragmentation, either successively or concurrently, together with the simultaneous addition of hydrogen fluoride to the unsaturated systems in some cases. The destruction of the aromatic character of the ring at the very outset, the fluorination of allylic

systems sensitive to substitution, and the stabilizing influence of resonating $-CF_2-$ and $-CF_3$ groups upon adjacent structures as well as the entire molecule, are significant factors which should not be overlooked in interpreting these changes. Also since added fluorine atoms would presumably be *trans* with respect to each other and therefore *cis* to adjacent hydrogen atoms, the intermediate products would be expected to resist β -elimination which is believed⁵ to take place by a *trans* mechanism, and so to favor the exchange reaction. This, together with the presence of $-CF_2-$ and $-CH_2-$ groups in these molecules, explains well the heretofore baffling failure of such compounds to return to aromatic systems on treatment with basic reagents.

Experimental

Apparatus.—The electrically heated metal reactor H used in this work was constructed from several pieces of brass pipe adequately capped, and is illustrated to scale in Fig. 1. It was equipped with two wide side arms, H' heated, and H'' unheated, exit tube J, sump tube I, and a Weston thermometer introduced into the middle of the reaction zone. The main body of the unit was fully packed with 2.7 kg. of mixed copper shot (Mallinckrodt no. 4644), and the side arms with 0.25" squares of copper gauze. The shot had greater weight of metal per unit volume, greater surface and less free space than packings previously used, and proved very efficient in moderating the reactions. In operation the sample entered on nitrogen at S, while the fluorine diluted with nitrogen came in at F₂, and it was a feature of this unit that each was well dispersed in the packing before mingling and reacting in the main body of the reactor H. The non-volatile prod-

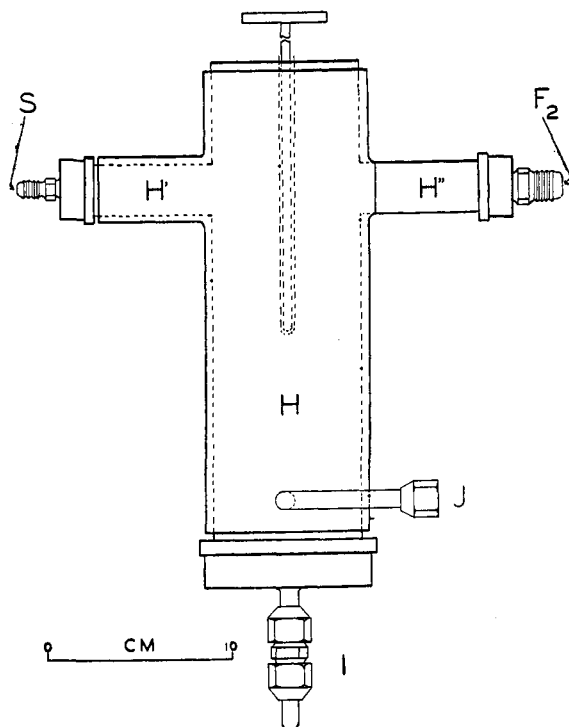

Fig. 1.—The reactor.

(5) Hammett, "Physical Organic Chemistry," McGraw-Hill Book Co., Inc., New York, N. Y., 1940, p. 181.

ucts collected at the bottom to be withdrawn later through I, while the volatile materials left through J and passed through a large electrically heated brass pipe, 31.5" × 2", packed with sodium fluoride pellets to remove hydrogen fluoride, after which they were condensed in a series of appropriately refrigerated glass traps properly protected from air and moisture. Two sodium fluoride tubes were used alternately and could be regenerated when exhausted by passing nitrogen through them at 300°. After each run the reactor was rinsed with acetone, dried by a current of nitrogen at elevated temperatures, and subjected to a current of fluorine to regenerate the metal halide surface.

The carefully calibrated electrically heated metal saturator used was constructed of brass pipe, properly capped, and is illustrated to scale in Fig. 2. It was equipped with a level regulator B, heated spray trap D, Weston thermometer introduced at an angle as shown, and was similar to one designed earlier in this laboratory by Holub. However, a special feature of this unit was a stainless steel dispersion disc of fine (Grade F) porosity, situated near the bottom below N₂, which served to break the incoming nitrogen into fine bubbles, thus making possible smaller samples and obviating fluctuations in the nitrogen flow meter. In operation the sample was introduced periodically at A and maintained at the standard level B, while the carrier nitrogen entered the dispersion unit at N₂, became partially saturated with the sample in C, deposited entrained spray in D (later to be returned to C through F), and left through G, carrying the sample at a known rate into the reactor.

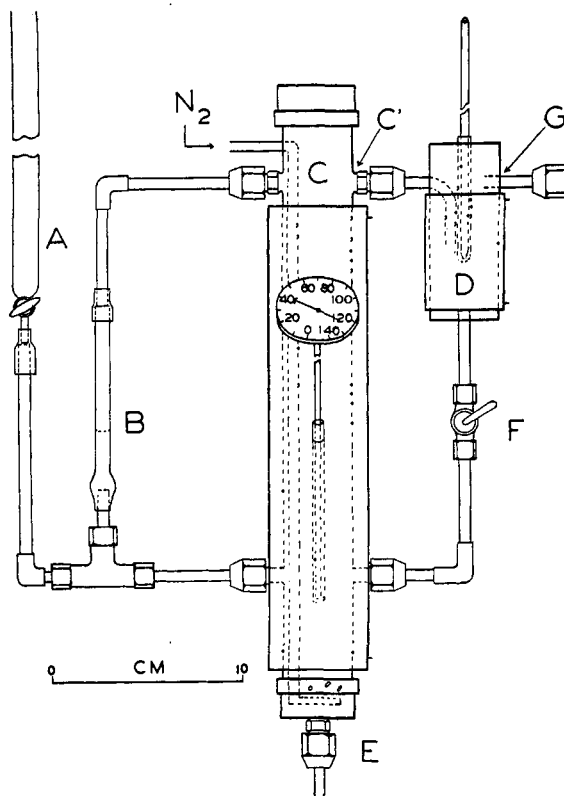

Fig. 2.—The saturator.

Materials.—The 1,4-bis-(trifluoromethyl)-benzene was prepared in quantity in this Laboratory in cooperation with Mr. J. B. Bond under the direction of Dr. C. K. Bradsher, by the total side-chain chlorination of *p*-xylene, followed by an exchange reaction using hydrogen fluoride under pressure and catalyzed by antimony pentachloride, phosphorus pentachloride and free chlorine. It boiled

at 115–116° and the over-all yield was 68%. The 1,3,5-tris-(trifluoromethyl)-benzene was synthesized in a similar manner by A. R. Gilbert, boiled at 119.5–120.5°, and the over-all yield was 40%. The benzotrifluoride and the 1,4-difluorobenzene were commercial products which on rectification boiled at 103° and 88°, respectively. The fluorine was produced by a Harshaw Chemical Company laboratory generator (Model L), and the output of pure fluorine was calculated on the basis of an electrical efficiency of 95%.

The Fluorination of 1,4-Bis-(trifluoromethyl)-benzene. Detailed Representative Procedure.—A total of 4.7 l. per hour of nitrogen was passed through the saturator (Fig. 2) at 58°, and carried a 0.03 mole sample into the reactor (Fig. 1) maintained at a base temperature 80°, where it met and reacted with 0.09 mole of fluorine carried in on 4.1 l. per hour of nitrogen. Accordingly the molar reaction ratio (F_2 :sample: N_2) was 3:1:12, corresponding to a reaction ratio of 3:1 and a dilution ratio of 1:4. The reaction zone temperature rose 6° over one-half hour, and was then cut back to 80° by reducing the external heat. The gaseous products were passed through the sodium fluoride tube at 110°, and were finally condensed first by Dry Ice and ultimately by liquid air. After forty-four hours, 283 g. of sample had been used, 244 g. of liquid and solid products had been condensed by Dry Ice and 3 ml. (mostly CF_4) by liquid air. At the half-way point and also at the end of the operating period, the apparatus was disassembled, the reactor heated to 150°, and the accumulated light yellow transparent liquid polymer drained, after which the packing was rinsed and dried. In all 95 g. of alkali sensitive polymer was formed which on cooling became a light colored brittle solid amounting to 28% of the total product. The periodic removal of the polymer was necessary since it competed with the sample for the incoming fluorine. The main product was completely freed from hydrogen fluoride as described before³ and separated into a relatively volatile portion b. p. 54–64° at 85 mm., 94 g.; a less volatile principal product b. p. 64–86° at 85 mm., 126.5 g.; and a residue which was discarded.

(a) **Reactions of the Principal Product**, b. p. 64–86° at 85 mm.—When dry gaseous ammonia was passed into a well stirred solution of 15.3 g. of principal product in 10.5 g. of *n*-pentane at –5 to 0° for two and one-half hours, the mixture turned red and deposited ammonium fluoride. It was then well washed with water and the organic layer separated and dried. After three-fourths of the solvent had been removed, a solid separated which was filtered, recrystallized twice from ligroin (70–90°) and finally separated in light yellow crystals, m. p. 171–172.5°.

Anal. Calcd. for $C_6H_5(NH_2)_3(CF_3)_2$, V: F, 38.6; mol. wt., 295; neut. equiv., 59.0. Found: F, 38.4; mol. wt., 298, 303; neut. equiv., 62.7.

NOTE.—All analyses in this paper were by Mrs. A. R. Gilbert to whom our grateful thanks are hereby expressed.

The material remaining in the red mother liquor was essentially all basic and contained insufficient fluorine to account for two $-CF_3$ groups. When the principal product was added to a suspension of potassium amide in ether, an immediate reaction occurred and some ammonia was evolved, but although the organic product was all basic, no chemical individuals could be isolated from it. Also when the principal product was refluxed in ethanol solution with an excess of zinc dust for fifty hours, it was recovered essentially unchanged.

(b) **The Catalytic Hydrogenation of the Principal Product.**—First, 20 g. of the original 1,4-bis-(trifluoromethyl)-benzene and 6 g. of Raney nickel were placed in the glass liner of a large rocking bomb and heated to 200° under a hydrogen pressure of 1700 lb./sq. in. for fourteen hours. After cooling, the catalyst was filtered off and the liquid product rectified in the Hyper-Cal column using a *p*-cymene chaser. There was obtained 12.7 g. (60% yield) of the expected 1,4-bis-(trifluoromethyl)-cyclohexane, b. p. 138–140°; analytical sample, f. p. –40°, b. p. 139.5°, n_D^{20} 1.3549.

Anal. Calcd. for $C_6H_{10}(CF_3)_2$, IX: F, 51.8; mol. wt., 220. Found: F, 51.7, 51.8; mol. wt., 218, 221.

Then 43.8 g. principal product in 32 g. methanol together with 6 g. of Raney nickel was heated in the bomb to 150 ± 5° at the same pressure for twelve hours, after which the catalyst was filtered off and the solvent removed. However, the product was sensitive to alkali, so it was hydrogenated twice more as before, but the final product (32 g.) was still sensitive. It was therefore dissolved in 20 g. of *n*-pentane and treated with dry ammonia. After removal of the pentane the residue was treated with dry hydrogen chloride in ether, the amine salts filtered off, and the solvent again removed, leaving a neutral brown liquid (12 g.) which was rectified using a *p*-cymene chaser. Two products were obtained, namely, 4 g. of IX, b. p. 138–140°, and 3 g. of colorless liquid 2,2-difluoro-1,4-bis-(trifluoromethyl)-cyclohexane, VIII, b. p. 127–129°; analytical sample, b. p. 128°, n_D^{20} 1.3485.

Anal. Calcd. for $C_6H_8F_2(CF_3)_2$, VIII: F, 59.4; mol. wt., 256. Found: F, 59.5, 59.5; mol. wt., 253, 255.

(c) **The Recycling of the Principal Product.**—First, 108 g. of 1,4-bis-(trifluoromethyl)-benzene was fluorinated under vigorous conditions at the rate 0.03 mole per hour and a molar reaction ratio 6:1:20 with a reaction zone temperature 188° until 140 g. of colorless liquid product had been obtained. No polymer was formed, all the fluorine reacted with the sample, and the product after processing was rectified as usual. In this way three significant fractions were obtained, which boiled at 100–102°, 23.4 g.; 107°, 3.5 g.; and 116.2°, 4.8 g., respectively. The first of these was the known perfluoro compound⁴ VII, b. p. 101°, while the other two were apparently stereoisomers of $C_6H_2F_8(CF_3)_2$, VI, which were alkali sensitive and would not crystallize.

Anal. Calcd. for $C_6H_2F_8(CF_3)_2$, VI: F, 73.1; mol. wt., 364. Found (107°): F, 73.3, 73.2; mol. wt., 363, 357. Found (116.2°): F, 73.0, 72.9; mol. wt., 363, 369.

The principal product was then recycled under these optimum conditions, and was introduced into the reactor through a capillary similar to that used by Fukuhara and Bigelow,⁶ calibrated to deliver 6 g. per hour of the sample. In this way 40 g. of principal product was fluorinated at the rate 0.02 mole per hour, at a fluorination ratio 10:1, a dilution ratio 1:3.5 and a reaction zone temperature 188° for 6.7 hours, after which the total colorless liquid product was processed and rectified. It yielded 27 g. of VII, b. p. 100–102°, or 68% based on the weight of sample utilized. This finding, together with the absence of $C_6H_{11}(CF_3)_2$ in the product, completed the proof that the original cyclic structure remained essentially intact during the fluorinations.

(d) **The Rectification of the Principal Product by Itself.**—This main product amounting to 127 g. was rectified in the Hyper-Cal column and yielded two significant non-crystalline, alkali sensitive fractions, b. p. 69.3° (5.4 g.), n_D^{20} 1.3250, and 72.0° (3.6 g.), n_D^{20} 1.3309 at 70.5 mm., respectively.

Anal. Calcd. for $C_6H_2F_8(CF_3)_2$, IV: F, 69.9; mol. wt., 326. Found: F, 69.9, 70.0; mol. wt., 326, 325. Calcd. for $C_6H_5F_5(CF_3)_2$, II: F, 67.4; mol. wt., 310. Found: F, 67.4, 67.4; mol. wt., 312, 314.

(e) **The Rectification of the More Volatile Portion**, B. p. 54–65° at 85 Mm.—A total of 94 g. of this material was carefully rectified at atmospheric pressure and yielded one significant, completely crystalline fraction, f. p. –15 to –16°, b. p. 111.5° (1.0 g.), n_D^{20} 1.3310, which was entirely inert toward alkaline reagents. It was significant that the fractions immediately preceding and following this one neither froze completely nor were inert to alkaline reagents.

Anal. Calcd. for $C_6H_2F_4(CF_3)_2$, III: F, 65.9; mol. wt., 288. Found: F, 65.7; mol. wt., 284, 286.

Unreacted sample, b. p. 115–116°, 30 g., was also isolated from this more volatile fraction.

(6) Fukuhara and Bigelow, *THIS JOURNAL*, **63**, 788 (1941).

The Fluorination of 1,3,5-Tris-(trifluoromethyl)-benzene.—This material was fluorinated at a molar reaction ratio of 3:1:12, saturator temperature 72° (5.0 l. of nitrogen per hour), reactor base temperature 92°, and reaction zone rise only 4°. In thirty-four hours 281 g. of sample was carried into the reactor at 0.03 mole per hour where it mingled with 0.09 mole of fluorine diluted with 3.8 l. of nitrogen per hour, and yielded 370 g. of liquid product. No polymer formed and only 4 ml. of CF₄ was collected. After processing, the crude material was distilled and yielded a principal product, b. p. 66.2–82° at 97 mm. (341 g.), which was rectified at reduced pressure. Three significant non-crystalline, alkali sensitive fractions were separated. They boiled at 64.5°, 5.7 g., *n*_D²⁰ 1.3238; 67.5°, 12.4 g., *n*_D²⁰ 1.3172; and 74.6°, 46 g., *n*_D²⁰ 1.3113, all at 106 mm.

Anal. Calcd. for C₆H₃F₄(CF₃)₃, X: F, 69.0; mol. wt., 358. Found: F, 69.1, 69.3; mol. wt., 356, 360. Calcd. for C₆H₂F₅(CF₃)₃, XI: F, 70.7; mol. wt., 376. Found: F, 70.6, 70.9; mol. wt., 375, 378. Calcd. for C₆H₂F₇(CF₃)₃, XII: F, 73.4; mol. wt., 414. Found: F, 73.5, 73.7; mol. wt., 415, 414.

It was demonstrated that X, XI and XII would not yield products which could be identified on treatment with ammonia in *n*-pentane solution, but the methoxide ion proved much more successful. When 6.6 g. of sodium was dissolved in 200 cc. dry methanol in a flask equipped with stirrer, condenser, drying tube and dropping funnel; and 14 g. of XII in 20 cc. methanol added over a period of one hour at –10 ± 2°, an immediate reaction occurred. The mixture was allowed to warm and 100 cc. of water added, causing an oil to separate, which was removed. The aqueous layer was extracted with ether and, after washing with water and drying, the solvent was removed, the residual oil combined with the main portion, after which the liquid (13 g.) was dried over magnesium sulfate and distilled at reduced pressure. A fraction was obtained, b. p. 103° at 9 mm., which was redistilled through a 4" Vigreux column and a central cut taken, which crystallized on standing. The use of seed crystals from this portion caused other fractions to crystallize in part so that in all 8.4 g. (53% yield) was collected. This material was recrystallized twice from 90% ethanol and finally separated in white crystals, m. p. 69.5–70.2°. This was a penta-methoxy compound indicating that five reactive fluorine atoms in XII had been replaced, while the other two must have been contained in a –CF₂– group.

Anal. Calcd. for C₆H₂F₂(OCH₃)₅(CF₃)₃, XVI: F, 44.1; mol. wt., 474. Found: F, 44.0, 44.0; mol. wt., 460, 465.

It was shown that XI could not be catalytically hydrogenated at high pressure successfully. However, when 20 g. of 1,3,5-tris-(trifluoromethyl)-benzene together with 6 g. of fresh Raney nickel were heated to 200° in the rocking bomb under a hydrogen pressure of 3500 lb./sq. in. for twenty hours, the product was a white solid which was recrystallized twice from 90% ethanol and separated in volatile white crystals, m. p. 59.2–59.8°, b. p. (micro) 157°. It weighed 17.5 g. representing an 86% yield of XV.

Anal. Calcd. for C₆H₉(CF₃)₃, XV: F, 59.3; mol. wt., 288. Found: F, 59.2, 59.5; mol. wt., 285, 284.

Finally, most of the fluorinated product excepting X, XI and XII was recycled using an inverted reactor with the sample, mixed with nitrogen, entering at a constant rate through I, where it volatilized and mingled within the meshes of the packing with the fluorine, also diluted with nitrogen, coming in at J. The molar reaction ratio was 6:1:20, the reaction zone temperature 164°, and under these vigorous conditions fluorine was always present in the exit gases at F₂. A combined sample of 130 g. yielded 145 g. of water-white product which was condensed and processed in the usual manner, and then rectified. Two significant fractions were obtained, one boiling at 124–125.5° (55 g.), mol. wt. 450, 452; and the other at 130° (6 g.), *n*_D²⁰ 1.3040, which was non-crystalline and alkali sensitive. The first of these was the known perfluoro

compound⁴ XIV, b. p. 125.2°, mol. wt., 450, while the second was the corresponding monohydroperfluoro compound.

Anal. Calcd. for C₆HF₈(CF₃)₃, XIII: F, 74.8; mol. wt., 432. Found: F, 74.6, 74.7; mol. wt., 429, 430.

The Fluorination of Benzotrifluoride.—This compound was fluorinated at the molar reaction ratio of 3:1:12, saturator temperature 48° (3.6 l. of nitrogen per hour), reactor base temperature 80°, and reaction zone rise 10°. In sixty-seven hours, 293 g. of sample was carried into the reactor at 0.03 mole per hour where it mingled with 0.09 mole of fluorine diluted with 5.2 l. of nitrogen per hour, and yielded 221 g. of liquid and solid product. During this period 4 ml. of CF₄ + C₂F₆ was collected, while 163 g. of light yellow, viscous polymer condensed on the surface of the reactor packing. After each 100 g. of sample had been fluorinated this polymer was drained and the packing renewed as described above. It solidified on cooling to a light yellow resinous alkali sensitive solid amounting to 42% of the total product. The crude product which was not very stable was processed as usual and kept cold. It was distilled into portions, one of which, b. p. 54° at 148 mm. to 86° at 78 mm. (75.2 g.), yielded two significant non-crystalline, alkali sensitive fractions when rectified. They boiled at 55° (2.5 g.), *n*_D²⁰ 1.3399, and 64.5° (2.5 g.), *n*_D²⁰ 1.3225, both at 162 mm.

Anal. Calcd. for C₆H₂F₄(CF₃)₃, XVII: F, 59.4; mol. wt., 224. Found: F, 59.5, 59.6; mol. wt., 218, 221. Calcd. for C₆H₄F₇(CF₃)₃, XVIII: F, 68.3; mol. wt., 278. Found: F, 68.1, 68.4; mol. wt., 278, 274.

The Fluorination of 1,4-Difluorobenzene.—This compound was fluorinated at a molar reaction ratio of 3:1:12, a reactor temperature 66°, and a reaction zone rise of 15°, later reduced. During twenty-four hours 83 g. of 1,4-difluorobenzene yielded 30 cc. of CF₄ and 58 g. of higher boiling products. Considerable combustion occurred within the reactor, but no polymeric material was deposited. The product, excluding the CF₄, was processed and rectified, yielding 6 cc. of C₆F₁₂, b. p. 50°, 24 g. of unreacted sample and no other significant products. Another run at the molar reaction ratio of 1.5:1:9 proved even less successful.

Summary

The fluorination of a series of progressively more and more deactivated aromatic compounds under mild conditions in a new type of reactor has been carried out, and the nature of the attack of elementary fluorine upon these varying structures has been discussed.

Benzotrifluoride formed two, 1,4-bis-(trifluoromethyl)-benzene gave five and 1,3,5-tris-(trifluoromethyl)-benzene yielded four new products containing more fluorine than the original substances, but the same skeletal structures.

It has been shown that when compounds of this kind are treated with basic reagents, the exchange reaction predominated greatly over β-elimination, as evidenced by the isolation of a penta-amino- and a penta-methoxy derivative in two instances. No return to an aromatic structure was observed at any time.

It has also been shown that a considerable body of quantitative data are entirely in accord with the assumption that after one fluorine atom has been added to a benzenoid system, the aromatic character of the ring is completely lost and it behaves subsequently as a substituted cyclohexadiene. As such it may undergo (a) addition of fluorine, (b) substitution by fluorine, (c) addition of

hydrogen fluoride, (d) polymerization, and (e) fragmentation, either concurrently or successively.

All of the new products just mentioned and a number of other related derivatives have been

adequately characterized with respect to both composition and molecular weight, but not necessarily with respect to such structural or stereoisomeric forms as may have been present.

DURHAM, NORTH CAROLINA RECEIVED JULY 18, 1949

[CONTRIBUTION FROM THE PULP MILLS RESEARCH PROJECT AND THE DEPARTMENT OF CHEMISTRY AND CHEMICAL ENGINEERING OF THE UNIVERSITY OF WASHINGTON]

Vapor-Liquid Equilibrium of Pyridine-Acetic Anhydride Solutions¹

BY PHILIP A. NELSON² AND AARON E. MARKHAM

Certain analytical methods for hydroxyl in organic compounds, such as that of Verley and Bölsing³ and its modifications, *e.g.*, that of Freed and Wynne,⁴ involve esterification using acetic anhydride in pyridine solution. The analyses are usually carried out under such conditions that even a small loss of acetic acid or anhydride vapors from the refluxing mixture would introduce serious errors into the result. Vapor-liquid equilibrium data for the systems acetic acid-pyridine, and acetic anhydride-pyridine, would be helpful in indicating the magnitude of the error introduced by the loss of a small amount of vapor. Data have been presented on the acetic acid-pyridine system by Swearingen and Ross.⁵ The present investigation was undertaken to obtain data on the acetic anhydride-pyridine system.

Experimental

Reagents.—Analytical grade reagents were used throughout. The acetic anhydride was fractionally distilled in a packed column before use, the first third, before the boiling point became constant, being discarded. Boiling points of 139.2° at 760.9 mm. and 138.2° at 756.6 mm. were observed, as compared with the value of 139.55° at 760 mm. reported by Orton and Jones.⁶ Analysis of the anhydride for acid by the method of Rott⁷ showed no acid, within the estimated limit of error of the method (0.2%). This method depends on a freezing point determination of the acetic acid produced by hydrolysis of the anhydride with a measured amount of water, and consequently should be quite sensitive to other impurities as well.

The pyridine had a boiling point of 115.6° at 756.6 mm., as compared to 115.5° at 760 reported by Timmermans.⁸ The fraction used boiled over a range of less than 0.05°. The densities of two different materials used were 0.97797 and 0.97781, respectively, as compared to 0.9776 reported in the literature.⁹ Distillation over barium oxide did not change the density of the pyridine.

(1) From a thesis submitted by Philip A. Nelson in partial fulfillment of the requirements for the degree of Bachelor of Science in Chemical Engineering.

(2) Seattle Gas Co., Seattle, Wash.

(3) Verley and Bölsing, *Ber.*, **34**, 3354 (1901).

(4) Freed and Wynne, *Ind. Eng. Chem., Anal. Ed.*, **8**, 278 (1936).

(5) Swearingen and Ross, *J. Phys. Chem.*, **39**, 821 (1935).

(6) Orton and Jones, *J. Chem. Soc.*, **101**, 1720 (1912).

(7) Rott, *Chem. Ztg.*, **54**, 954 (1930).

(8) Timmermans, *Bull. soc. belg. chim.*, **24**, 244 (1910).

(9) Jones and Speakman, *THIS JOURNAL*, **43**, 1867 (1921); Müller and Brenneis, *Z. Elektrochem.*, **38**, 450 (1932).

Apparatus.—The equilibrium still used was a modification of that described by Jones, Schoenborn and Colburn.¹⁰ A central tube, characteristic of the Othmer still,¹¹ was installed in the upper part of the boiling chamber to provide adiabatic insulation for the vapors and thus prevent reflux. A vent was provided to remove non-condensable gas from the space outside the central tube. When the apparatus was applied to the ethanol-water system to check its performance, with 16.5 mole per cent. ethanol in the liquid, the vapor composition was found to be 50.1% ethanol and the boiling point 83.5° at 756.3 mm. as compared with 50.3% ethanol and 83.9° at 760 mm. interpolated from the data of Jones, *et al.*¹⁰

Analysis.—The samples of liquid and condensed vapor withdrawn from the still were analyzed by hydrolyzing the acetic anhydride with water and titrating the product with carbonate-free sodium hydroxide to the phenolphthalein end-point.

Equilibrium and Boiling Point Data

The experimental boiling point and vapor-liquid composition data are presented in Fig. 1, in which the solid line is the composition curve according to Raoult's law. The water content was ignored in the calculation of the mole fractions. For the vapor pressures of the pure materials required in the calculations, the equation of Van der Meulen and Mann¹²

$$\log p = 6.8827 - (1281.3/(t + 203))$$

was used for pyridine, and the equation

$$\log p = 8.2899 - 2232.4/(t + 273.2)$$

obtained from vapor pressure data at 100°¹³ and 139.55°⁴ was used for acetic anhydride.

Discussion

The solutions were observed to darken on boiling due to the formation of a small amount of tar. This tar formation was observed by Wilson and Hughes,¹⁴ who reported that it resulted from the use of anhydrous pyridine and could be prevented by the addition of about 0.5% of water to the pyridine before mixing with the acetic anhydride. A sample of a mixture, which had been boiled for several hours in the still while being

(10) Jones, Schoenborn and Colburn, *Ind. Eng. Chem.*, **35**, 666 (1943).

(11) Othmer, *Ind. Eng. Chem., Anal. Ed.*, **20**, 763 (1948).

(12) Van der Meulen and Mann, *THIS JOURNAL*, **53**, 451 (1931).

(13) Beckmann and Liesche, *Z. physik. Chem.*, **88**, 419 (1914).

(14) Wilson and Hughes, *J. Soc. Chem. Ind.*, **58**, 74 (1939).